

# Vulcan® Barrier

## STEEL BARRIERS



## Vulcan® Barrier

The Vulcan® is a portable, longitudinal redirecting steel barrier made of lightweight, galvanized steel segments. It is tested to NCHRP Report 350 Test Level 3 and Test Level 4, and EN 1317 H2 and N2. The Vulcan® Barrier can be used in permanent and work zone applications with other compatible end treatments such as the QuadGuard®, QUEST®, TRACC®, or ACZ 350®.



### FEATURES

- Can be deployed with multiple anchoring configurations, as a gate or free standing.
- Designed to help reduce work zone congestion in high traffic areas by creating temporary lane shifts and work zone closures during off-peak or weekend hours.
- Can be used as a temporary or permanent median or roadside longitudinal barrier.
- Vertical steel pivot pin interlinks each module.
- Optional wheels and jacks for more efficient transportation by hand or towing short distances with a vehicle.

### ASSEMBLY AND MAINTENANCE

- Lightweight, modular design for transportation of up to 480 linear feet of barrier per standard truckload.
- Attachment to a skid steer or front-end loader allows the movement of one mile of Vulcan® Barrier approximately one lane-width in about 20 minutes.

### SPECIFICATIONS

- Typical 13' 6" (4 m) Long Segments
- 39' (12 m) Segments Also Available
- 21.5" Wide (546 mm)
- 32" High (813 mm)
- 1,020 lbs. (460 kg)

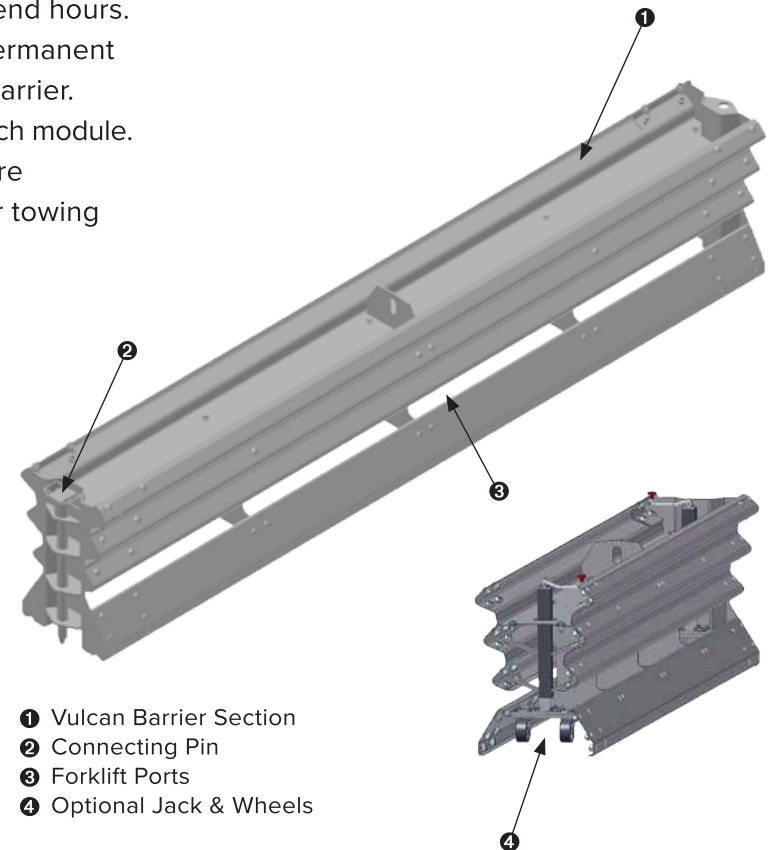

- ❶ Vulcan Barrier Section
- ❷ Connecting Pin
- ❸ Forklift Ports
- ❹ Optional Jack & Wheels

DISTRIBUTED BY