

ArmorZone[®] TL-2

WATER-FILLED BARRIER



MASH TESTED

ArmorZone® TL-2

The ArmorZone® TL-2 is a portable, temporary, high performance plastic water filled barrier for redirective applications. The barrier system consists of interlocking 6' 7" (2 m) barrier sections made of high performance polyethylene plastic and galvanized steel connecting pins.

The ArmorZone® is tested to MASH Test Level 2.



FEATURES

- MASH TL-2 work zone barrier protection.
- Quick and easy install.
- 78 barrier sections per flatbed truck.
- 84 barrier sections per 40' HC container.
- Environmentally friendly - 100% recycleable.
- Stabilized HDPE modules may be reusable after light impacts.*
- Water level indicator.
- Fill hole screen prevents garbage build up within barrier.
- Lightweight sections.
- Convenient forklift ports and fill level indicator.

DEPLOYMENT STEPS

- Unload
- Position and pin
- Fill with water

- 1 Dual Steel Connecting Pin
- 2 Fill Hole With Lid
- 3 Water Level Indicator
- 4 Forklift Ports
- 5 Stabilized HDPE Barrier Section

SPECIFICATIONS

- 7' 1" (2.2 m) Total Length
- 6' 7" (2 m) Effective Length
- 18" (450 mm) Wide
- 34" (860 mm) High
- 123 lbs. (56 kg) Empty Weight
- 1,093 lbs. (496 kg) Ballasted Weight
- 116 gal. (440 L) Ballast Capacity
- 25 Section Minimum Deployment Length

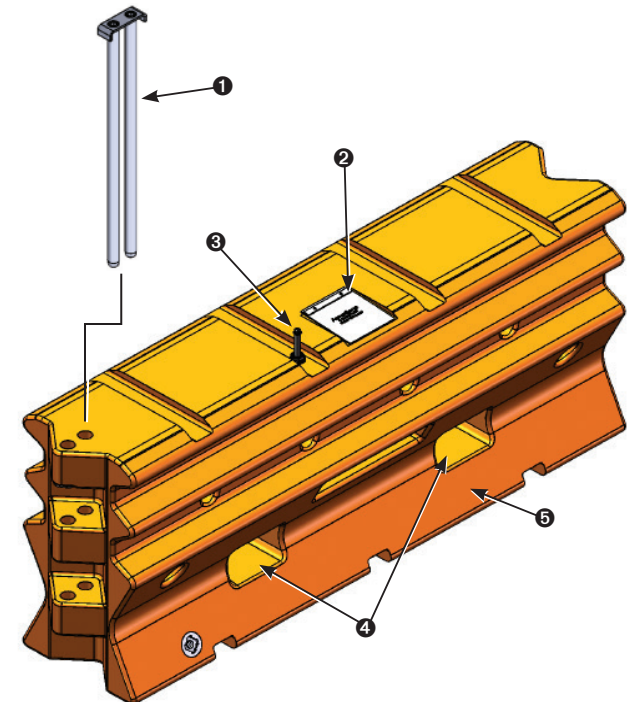

DISTRIBUTED BY