

MPS 350[®] X

TRUCK MOUNTED ATTENUATOR



MPS 350[®] X

The MPS 350[®] X is a galvanized, cantilevered truck mounted attenuator for use on stationary or moving shadow support vehicles. This compact TMA is tested to NCHRP Report 350 Test Level 3. Additionally, the MPS 350[®] X is further tested to the UK TD 49 (110 km/h) standard. The unit is made of galvanized steel components with an open frame design that helps facilitate inspection and maintenance. The MPS 350[®] X is designed to help absorb rear-end impacts at speeds up to 62 mph (100 km/h) when impacted within NCHRP Report 350 crash test standards.

ASSEMBLY AND MAINTENANCE

- Compact system for more efficient transport and staging.
- Convenient swivel jacks and casters for more efficient mounting, dismounting, and moving to storage.
- Open frame design helps facilitate inspection, maintenance, or repair.*
- Replaceable bump stops.
- Contained debris field after an impact within NCHRP Report 350 crash test standards.

FEATURES

- Standard galvanized system. Black and yellow powder coated systems available.
- Open frame design helps facilitate inspection and less wind resistance.
- Durashell[®] strike plate cover made of heavy-duty plastic designed to help minimize damage from nuisance hits.
- Mounting options include fixed tailgate hitch, and socket hitch receiver.
- In-cab control options available.
- Warning buzzer designed to help alert crews when unit is not fully deployed or in upright position.
- FMVSS 108 lighting system.

SPECIFICATIONS

- 14' (4.30 m) Operating Position Length
- 12' 5" (3.78 m) Raised Height
- 69" (1.76 m) Width
- 1,680 lbs. (762 kg) Weight

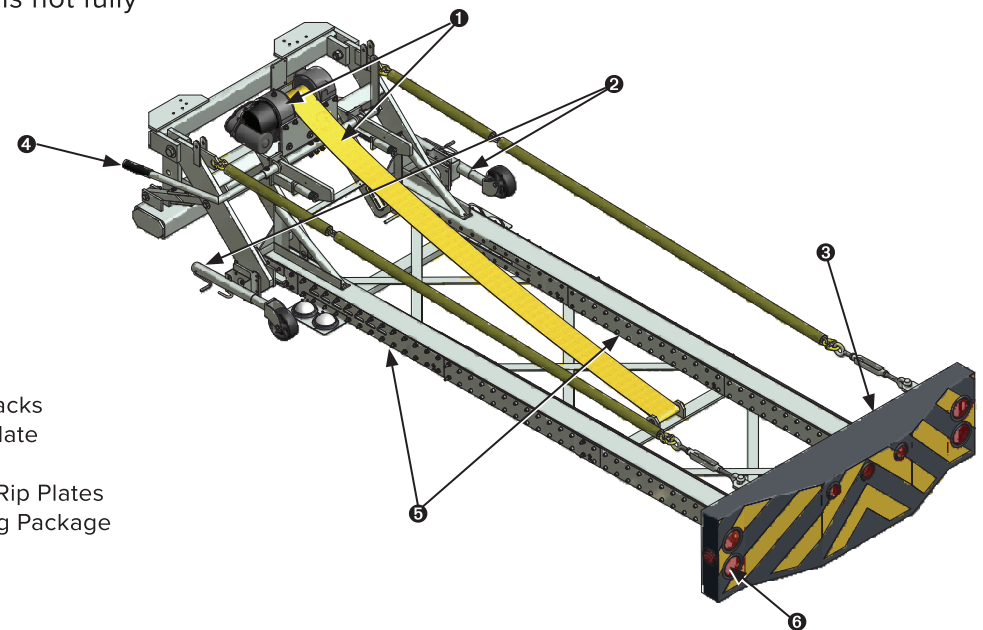

- 1 Winch & Strap
- 2 Swivel Casters & Jacks
- 3 Durashell[®] Strike Plate
- 4 Latch Bar
- 5 Energy Absorbing Rip Plates
- 6 FMVSS 108 Lighting Package

DISTRIBUTED BY