

CAT[®] 350

END TERMINAL



CAT® 350

The Crash Cushion Attenuating Terminal (CAT®) is an energy absorbing attenuator or end treatment available for use where blunt ends of rigid barriers, W-beam, and fixed objects are in the median or on the shoulder. It is tested to NCHRP Report 350 Test Level 3.



FEATURES

- CAT® 350 can be used as a W-beam barrier end treatment or as a crash cushion either in the median or on the shoulder.
- Various post and post/sleeve options are available.
- Durable galvanized components.

ASSEMBLY AND MAINTENANCE

- Soil installation.
- Does not use concrete pads.
- Does not use foundations and deadmen anchors.
- No torque requirements on bolts.
- Although all crash dynamics are unique, hardware at or below grade are potentially undamaged after impact so only major components need to be repaired or replaced.*

SPECIFICATIONS

- System Length: 31' 3" (9.52 m)
- System Width Inside: 22.5" (572 mm)
- System Width Outside: 29" (737 mm)
- System Height: 27.75" (705 mm)
- Total Number of Breakaway Posts: 6
- Redirective Capability (LON) Begins at Post 4 from Nose

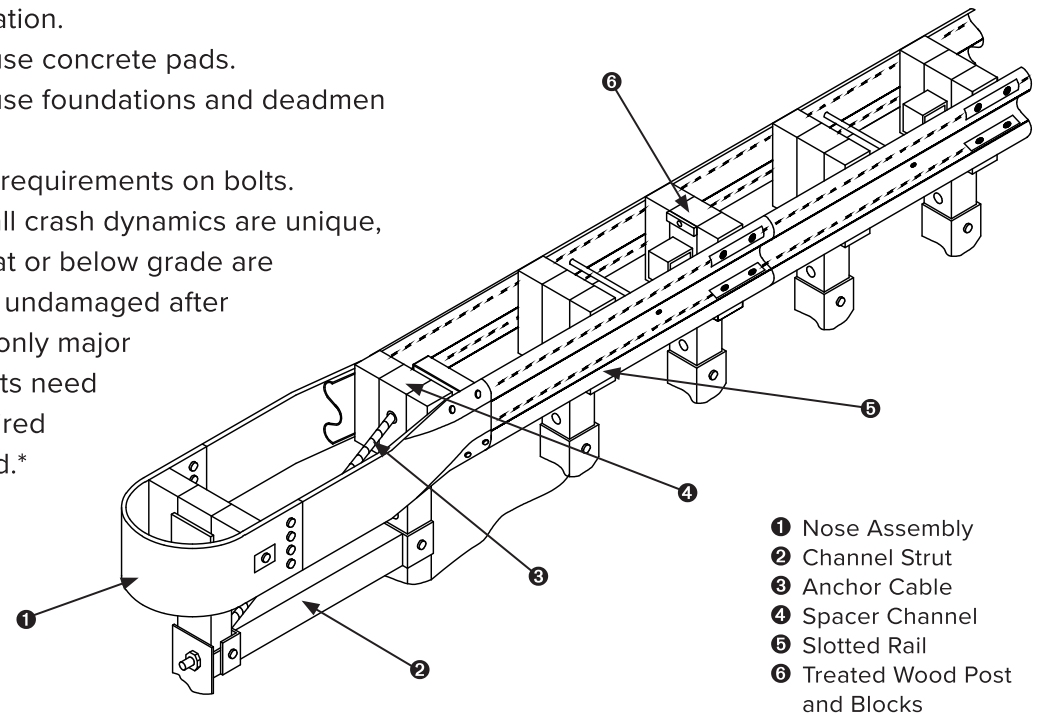

DISTRIBUTED BY